



V.le dell'Appennino, 606 B
47121 - Forlì - ITALIA
Tel. 0543-86066
Fax 0543-83418
R.E.A. FO n. 114469

URL <http://www.rinieri.com>
E-Mail : rinieri@rinieri.com
Capitale Sociale € 98.800 i.v.
Partita IVA CEE: IT 00012520409
Iscr. Reg.Impr. Fo / P. IVA e Cod. Fisc. 00012520409

BRM

150



**Parti di ricambio - Spare parts - Pièces de rechange
Ersatzteile - Piezas de repuesto**

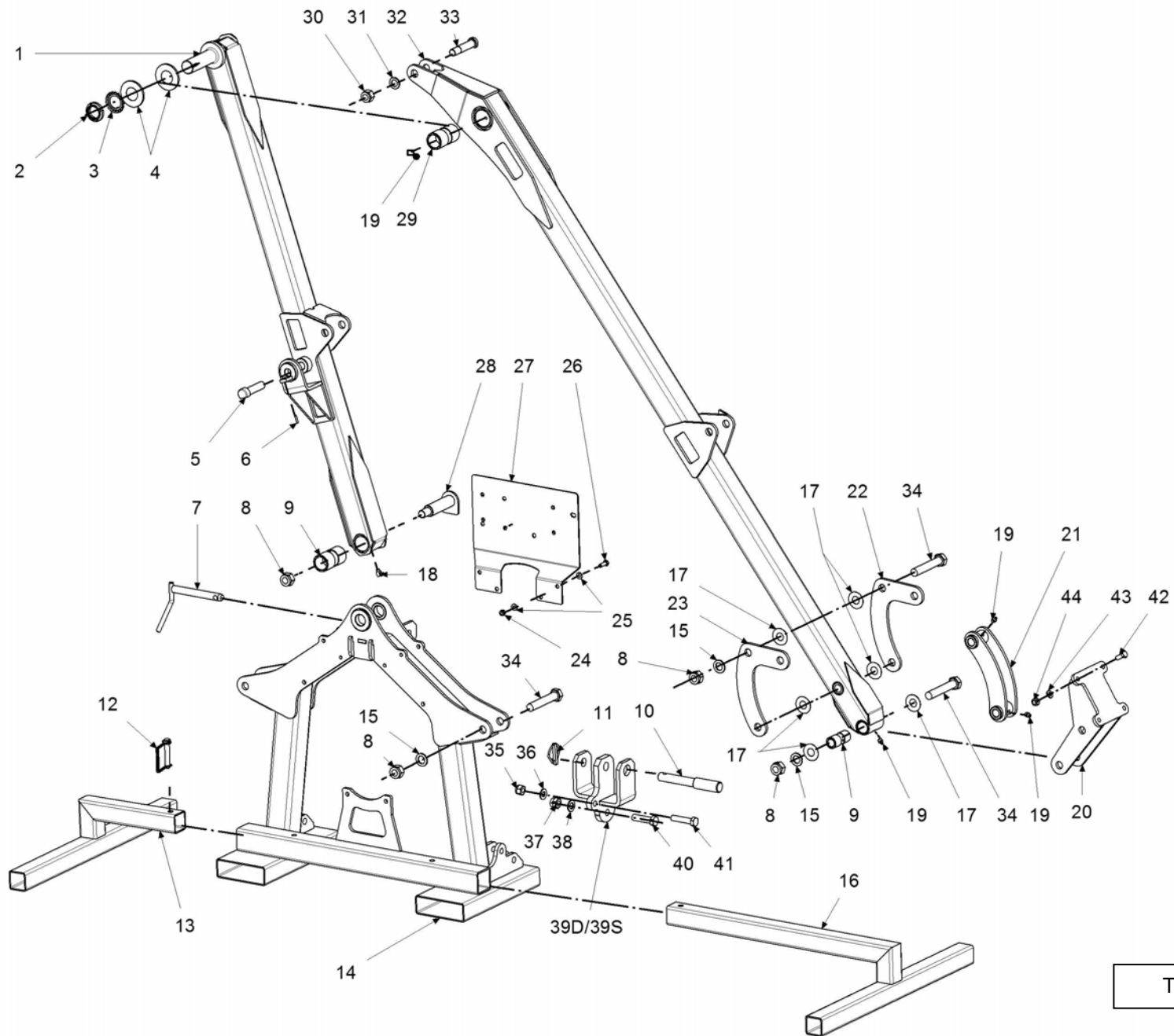

TAV.1/D

Parti di Ricambio “ BRM 150 “

Telaio BRM

Tavola 1/D – Pagina 1

N°	Codice	Descrizione	English	Français	Deutsch	Español
1	3850200B	Braccio BRM serie 2011	Arm	Bras	Arm	Soporte macho
2	0633135	Ghiera autobloccante normale 35x1,5	Ring Nut	Ecrou	Würfel	Dado
3	0660835	Rosetta di sicurezza MB 7 d.35	Washer	Rondelle	Scheibe	Roseta
4	37847	Spessore con smusso	Washer	Rondelle	Scheibe	Roseta
5	01618	Perno d.19x75	Pin	Pivot	Stütze	Perno
6	0662005045	Spina elastica Ø5x45 UNI 6873	Spring-pin	Goupille à ressort	Federsplint	Seguro a resorte
7	04034	Perno universale d.19-25 spina con catena	Pin	Pivot	Stütze	Perno
8	0631020	Dado autobloccante normale PG M20 UNI 7473	Nut	Ecrou	Würfel	Dado
9	37867	Boccola cementata Ø30x20 L.70	Bush	Bague	Buchse	Casquillo
10	37865	Perno sollevatore BRM	Pin	Pivot	Stütze	Perno
11	0664010	Spina a scatto d.10 tipo pera 28-36	Spring-pin	Goupille à ressort	Federsplint	Seguro a resorte
12	0664112	Perno per piedino d.12 60-40	Pin	Pivot	Stütze	Perno
13	37876	Piede corto	Foot	Pied	Fuß	Pie
14	3850100B	Castello BRM serie 2012	3 point attachment	3 points attaque	3-Punkt Angriff	3 puntos ataque
15	0660020	Rosetta piana 20 UNI 6592 Zincata	Washer	Rondelle	Scheibe	Roseta
16	37875	Piede Lungo	Foot	Pied	Fuß	Pie
17	37864	Rasamento Ø20 zincato	Thickness	Distancer	Dicke	Espesor
18	0673208100	Ingrassatore piegato 90° PF 8*1 UNI 7663 C	Grease nipple	Graisser	Gerader Öler	Engrasador
19	0673008100	Ingrassatore diritto PF 8*1 UNI 7663 A	Grease nipple	Graisser	Gerader Öler	Engrasador
20	37860	Attacco alla barra BRM	Attachment	Attelage	Anschluss	Eganche
21	37850	Secondo cinematismo BRM	Attachment	Attelage	Anschluss	Eganche
22	37852	Lamiera cinematismo BRM con fermi	Plate	Plaque	Platte	Chapa
23	37851	Lamiera cinematismo BRM	Plate	Plaque	Platte	Chapa
24	0631008	Dado autobloccante normale PG 8 UNI 7473	Nut	Ecrou	Würfel	Dado
25	0660008	Rosetta piana 8 UNI 6592 Zincata	Washer	Rondelle	Scheibe	Roseta
26	0642008030	Vite TE PG 8x30 MF UNI5737	Screw	Vis	Schraube	Tornillo
27	3850001A	Lamiera sostegno distributore	Support	Soutenir	Unterstützen	Apoyar
28	37843	Perno con blocco BRM	Pin	Pivot	Stütze	Perno
29	3850003A	Boccola cementata D.45 d.35 L.86	Bush	Bague	Buchse	Casquillo
30	0631018	Dado autobloccante normale PG 18 UNI 7473	Nut	Ecrou	Würfel	Dado
31	0660018	Rosetta piana 18 UNI 6592 Zincata	Washer	Rondelle	Scheibe	Roseta
32	3850300B	Secondo braccio BRMserie 2011	Arm	Bras	Arm	Soporte macho
33	3850002A	Perno per martinetto parte alta BRM	Pin	Pivot	Stütze	Perno
34	0643020120	Vite TE PG 20x120 MF L.25	Screw	Vis	Schraube	Tornillo
35	0631014	Dado autobloccante normale PG 14 UNI 7473	Nut	Ecrou	Würfel	Dado
36	0660014	Rosetta piana 14 UNI 6592 Zincata	Washer	Rondelle	Scheibe	Roseta
37	0631016	Dado autobloccante normale PG 16 UNI 7473	Nut	Ecrou	Würfel	Dado

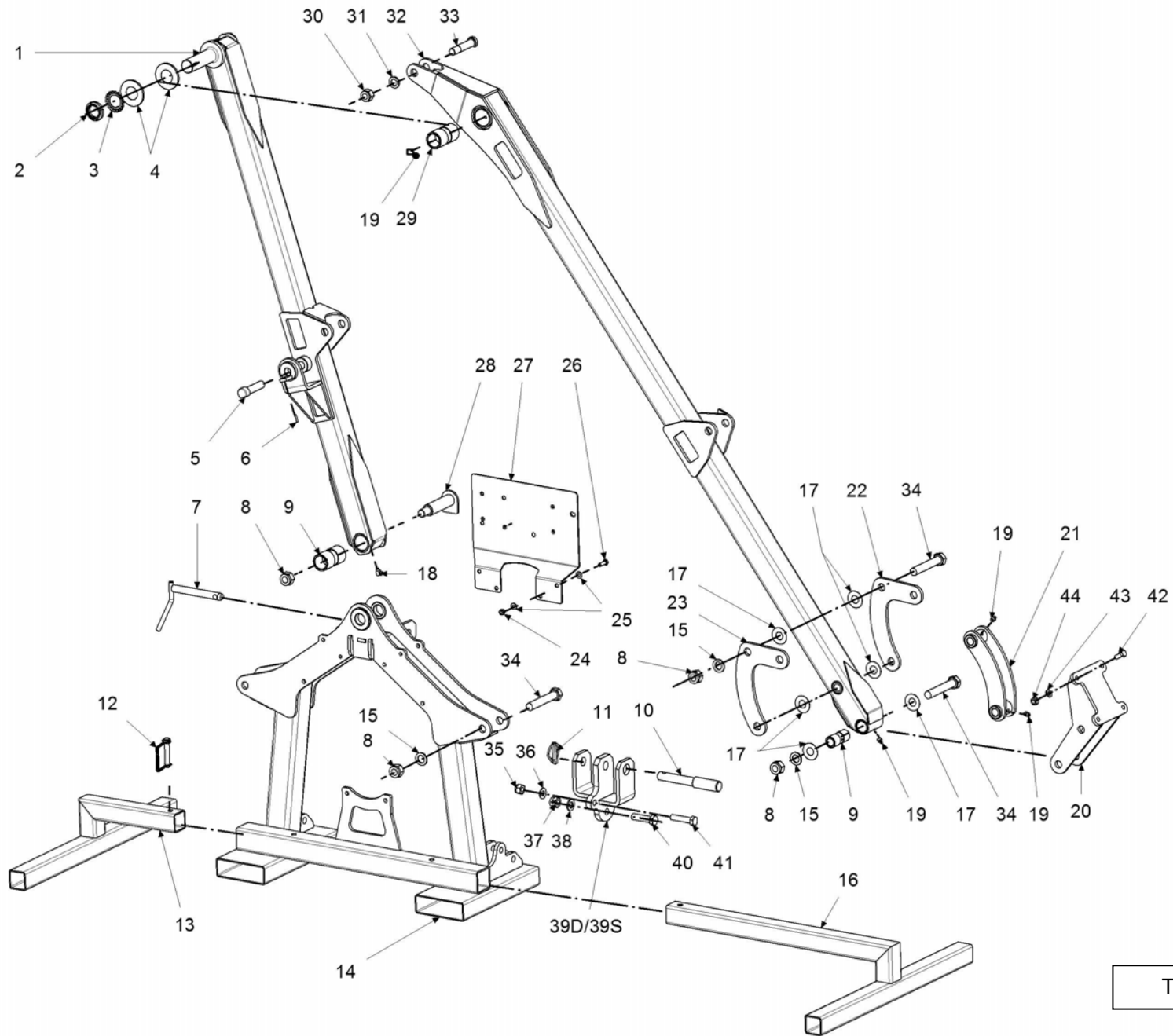

TAV.1/D

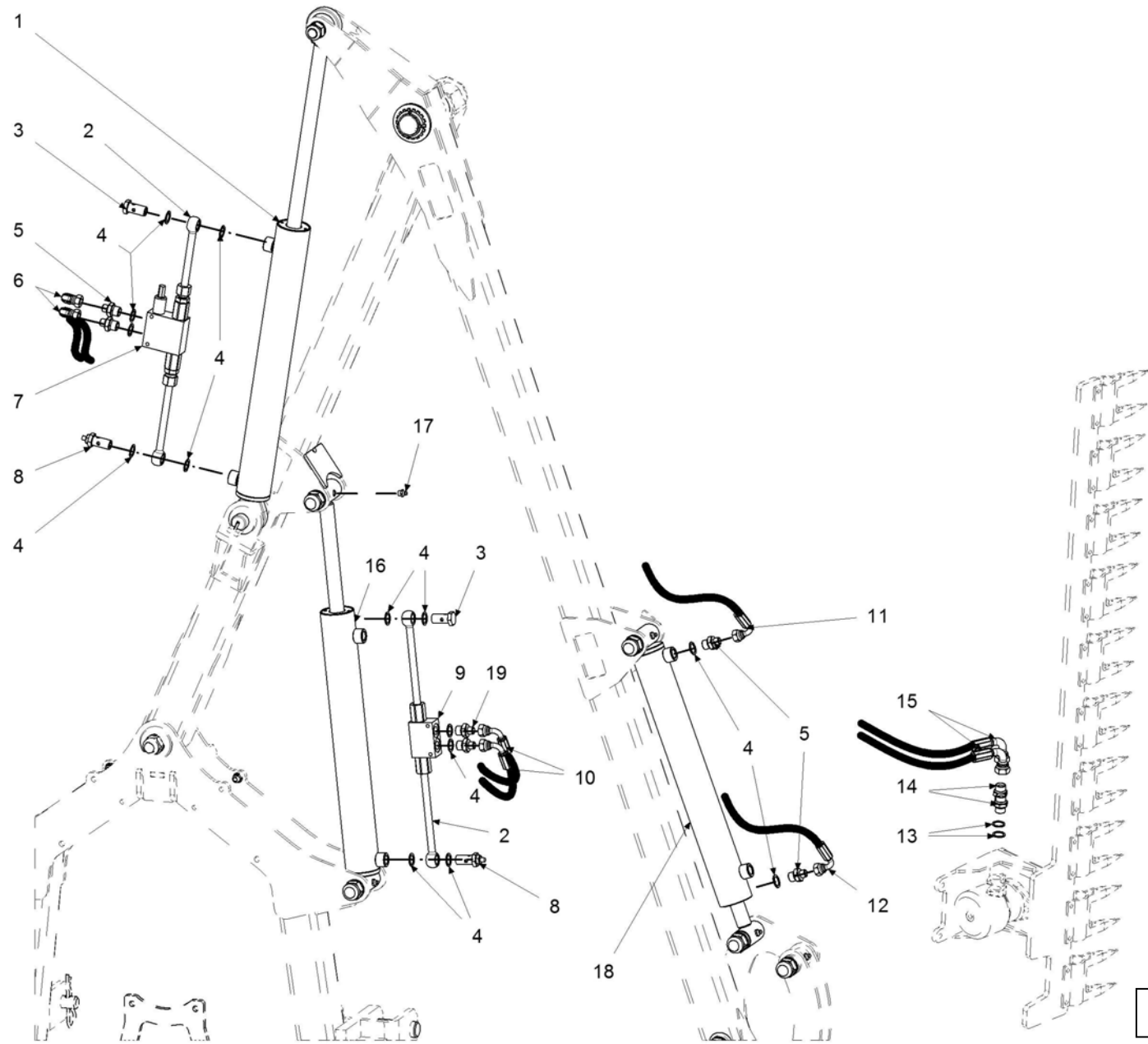

TAV.2/B

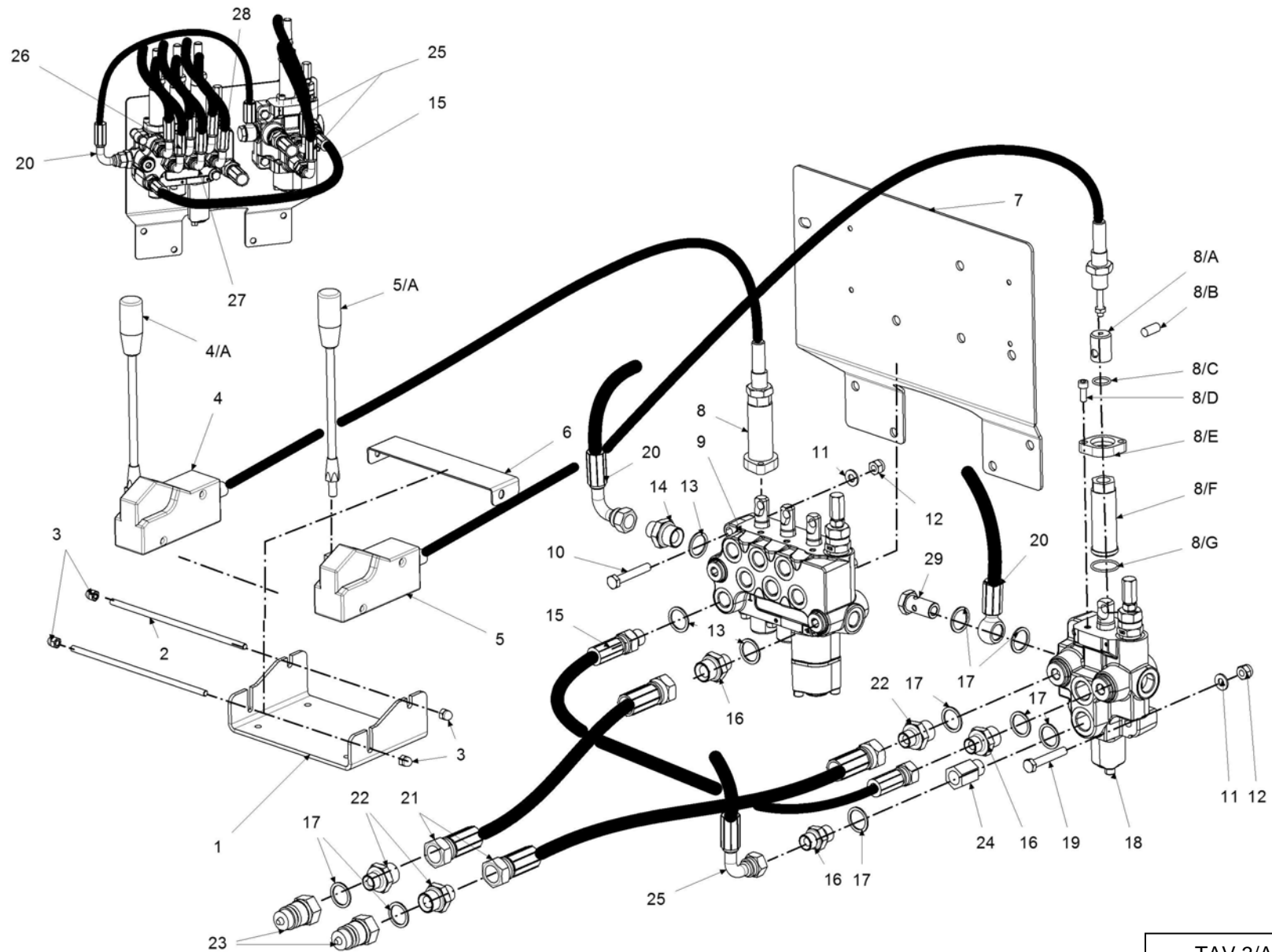

TAV.3/A

Parti di Ricambio “ BRM 150 “

Impianto idraulico per BRM

Tavola 3/A – Pagina 1

N°	Codice	Descrizione	English	Français	Deutsch	Español
1	37878	Staffa leve	Attachment	Attelage	Anschluss	Enganche
2		Barra filettata PG 6 DX L. DIN 975	Screw	Vis	Schraube	Tornillo
3	0625006	Dado cieco PG 6 calotta sferica UNI 5721	Nut	Ecrou	Schrauben-mutter	Dado
4	3789825	Kit leva cavo L.2500 e guaina per movimenti	Lever kit	Kit Levier	Hebel Kit	Kit Palanca
4/A	378982501	Leva per comando movimenti	Lever	Levier	Hebel	Palanca
5	3789925	Kit leva antinversione con pomello rosso cavo L.2500 e guaina per motore	Lever kit	Kit Levier	Hebel Kit	Kit Palanca
5/A	378992501	Leva con pomello rosso per motore	Lever	Levier	Hebel	Palanca
6	37879	Staffa adesivi leve	Attachment	Attelage	Anschluss	Enganche
7	3850001A	Staffa distributori	Attachment	Attelage	Anschluss	Enganche
8	00553	Accoppiatore distributore-cavo	Joint	Couplage	Kopplung	Acoplamiento
9	00551	Distributore ML/3 per movimenti	Distributor	Distributeur	Händler	Distribuidor
10	0642008060	Vite TE PG 8x60 MF UNI 5737	Screw	Vis	Schraube	Tornillo
11	0660008	Rosetta piana 8 UNI 6592	Washer	Rondelle	Scheibe	Roseta
12	0631008	Dado autobloccante normale 8 UNI 7473	Nut	Ecrou	Schrauben-mutter	Dado
13	0611238	Rondella in rame 3/8	Washer	Rondelle	Scheibe	Roseta
14	061013838	Niples M+M 3/8x3/8	Niples	Niples	Niples	Niples
15	060520502212	Tubo 3/8 R1T F+M 3/8 L.500	Hose	Tuyau	Schlauch	Tubo
16	061011238	Niples M+M 1/2x3/8	Niples	Niples	Niples	Niples
17	0611212	Rondella in rame 1/2	Washer	Rondelle	Scheibe	Roseta
18	00552	Distributore DN/1 per motore	Distributor	Distributeur	Händler	Distribuidor
19	0642008050	Vite TE PG 8x50 MF UNI 5737	Screw	Vis	Schraube	Tornillo
20	060520505342	Tubo 3/8 R1T occhio 1/2 + F.90 3/8 L.500	Hose	Tuyau	Schlauch	Tubo
21	060531202323	Tubo 1/2 R1T F+F 1/2 L.1200	Hose	Tuyau	Schlauch	Tubo
22	061011212	Niples M+M 1/2x12	Niples	Niples	Niples	Niples
23	0611712	Attacco rapido maschio 1/2	Attachment	Attelage	Anschluss	Enganche
24	061031202	Colonna M+F 1/2 bassa H.19	Connection	Jonction	Anschluss	Empalme
25	060524404242	Tubo da 3/8 R1T F.90 + F.90 3/8 L.4400 motore barra	Hose	Tuyau	Schlauch	Tubo
26	060510704141	Tubo 1/4 R1T F.90 + F.90 1/4 L.700 spostamento laterale	Hose	Tuyau	Schlauch	Tubo
27	060511254141	Tubo 1/4 R1T F.90 + F.90 1/4 L.1250 spostamento verticale	Hose	Tuyau	Schlauch	Tubo
28	060513004141	Tubo 1/4 R1T F.90 + F.90 1/4 L.3000 inclinazione barra	Hose	Tuyau	Schlauch	Tubo
28	060513454141	Tubo 1/4 R1T F.90 + F.90 1/4 L.3450 inclinazione barra	Hose	Tuyau	Schlauch	Tubo
29	0610412	Bullone forato 1/2	Screw	Vis	Schraube	Tornillo

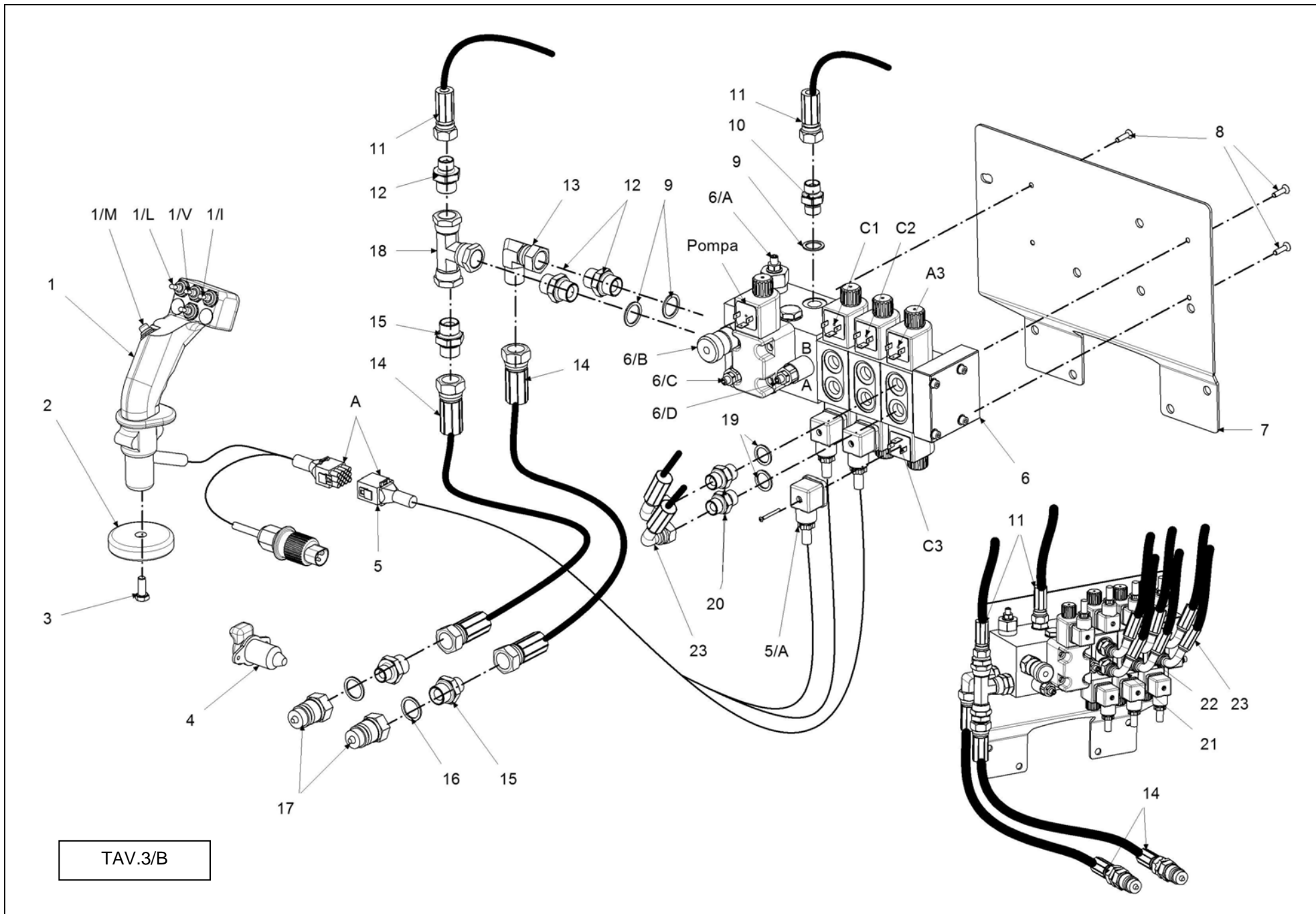

TAV.3/B

Parti di Ricambio “ BRM 150 “

Impianto elettro idraulico con joystick per BRM

Tavola 3/B – Pagina 1

N°	Codice	Descrizione	English	Français	Deutsch	Español
A	18120	Joystick 3+1 movimenti completo con cavo e magnete	Joystick	Manipulateur	Manipulator	Manipulador
1	1812080	Joystick 3+1 movimenti con alimentazione	Joystick	Manipulateur	Manipulator	Manipulador
1/M	1812004	Interruttore a pulsante joystick azionamento motore	Switch	Commutateur	Schalter	Interruptor
1/L	1812003	Interruttore a leva joystick comando spostamento laterale	Switch	Commutateur	Schalter	Interruptor
1/V	1812003	Interruttore a leva joystick comando spostamento verticale	Switch	Commutateur	Schalter	Interruptor
1/I	1812003	Interruttore a leva joystick comando inclinazione barra	Switch	Commutateur	Schalter	Interruptor
2	181010571	Magnete D.71 foro d.10,5 per joystick	Magnet	Aimant	Magnet	Imán
3	0651012030	Vite TSCE 12x30 UNI 5933	Screw	Vis	Schraube	Tornillo
4	18180	Presa femmina 3 poli Socket 25 A 905049	Plug	Fiche	Stecker	Enchufe
5	1812079	Cavo completo joystick con attacco femmina	Wire	Cable	Kabel	Cable
5/A	1810107	Connettore C18 3P+T 12V per elettrovalvola	Plug	Fiche	Stecker	Enchufe
6	00535° BRM**	Blocco elettrovalvole 3+1 diretto 12V	Distributor	Distributeur	Händler	Distribuidor
6/A		Valvola di massima pressione sulla mandata	Maxi. valve	Valve max.	Max Ventilhub	Válvula max
6/B		Regolatore di flusso per i motori	Regulator	Regulator	Regler	Regulador
6/C		Valvola di massima pressione per i motori	Maxi. valve	Valve max.	Max Ventilhub	Válvula max
6/D		Valvola di massima pressione per i movimenti	Maxi. valve	Valve max.	Max Ventilhub	Válvula max
7	3850001A	Staffa distributori	Attachment	Attelage	Anschluss	Enganche
8	0651005016	Vite TSCE 5x16 UNI 5933	Screw	Vis	Schraube	Tornillo
9	0611238	Rondella in rame da 3/8	Washer	Rondelle	Scheibe	Roseta
10	061013838	Niples M+M 3/8x3/8	Niples	Niples	Niples	Niples
11	060524254222	Tubo 3/8 R1T F.90 3/8 + F.3/8 L.4250 motore barra	Hose	Tuyau	Schlauch	Tubo
12	061011238	Niples M+M 1/2x3/8	Niples	Niples	Niples	Niples
13	0612512	Adattatore a 90°maschio 1/2 cilindrico + conico	Adapter	Adaptateur	Adapter	Adaptador
14	060531202323	Tubo 1/2 R1T F+F 1/2 L.1200	Hose	Tuyau	Schlauch	Tubo
15	061011212	Niples M+M 1/2x1/2	Niples	Niples	Niples	Niples
16	0611212	Rondella in rame da 1/2	Washer	Rondelle	Scheibe	Roseta
17	0611712	Attacco rapido maschio 1/2	Attachment	Attelage	Anschluss	Enganche
18	0614312	Raccordo a T 1/2 F. girevole	Adapter	Adaptateur	Adapter	Adaptador
19	0611214	Rondella in rame da 1/4	Washer	Rondelle	Scheibe	Roseta
20	061011414	Niples M+M 1/4x1/4	Niples	Niples	Niples	Niples
21	060510704141	Tubo 1/4 R1T F.90 + F.90 1/4 L.700 spostamento laterale	Hose	Tuyau	Schlauch	Tubo
22	060511254141	Tubo 1/4 R1T F.90 + F.90 1/4 L.1250 spostamento verticale	Hose	Tuyau	Schlauch	Tubo
23	060513004141	Tubo 1/4 R1T F.90 + F.90 1/4 L.3000 inclinazione barra	Hose	Tuyau	Schlauch	Tubo
23	060513454141	Tubo 1/4 R1T F.90 + F.90 1/4 L.3450 inclinazione barra	Hose	Tuyau	Schlauch	Tubo

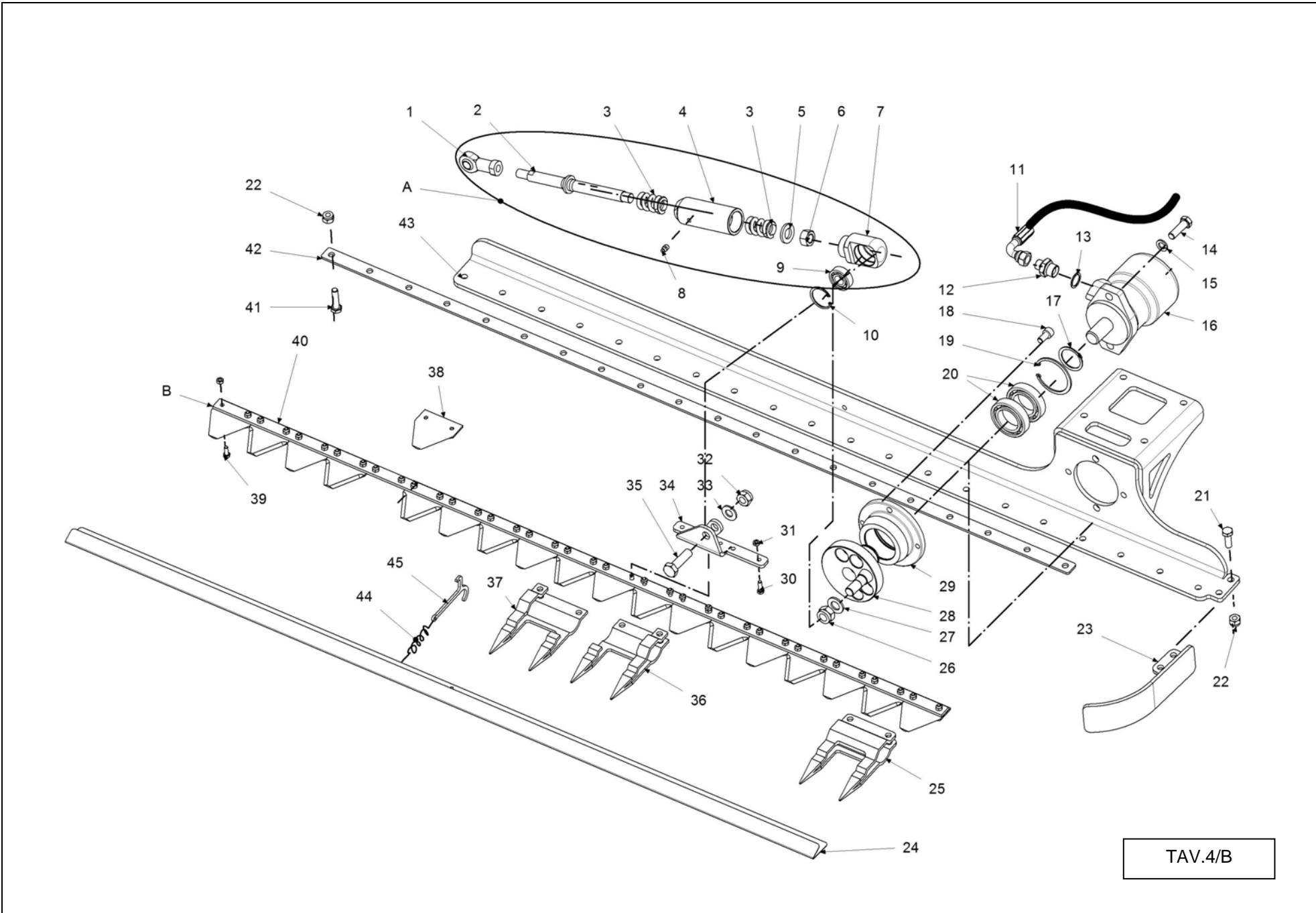

TAV.4/B

Parti di Ricambio “ BRM 150 “

Barra di taglio a Lame 6BT030150

Tavola 4/B – Pagina 1

N°	Codice	Descrizione	English	Français	Deutsch	Español
A	3850512A	Biella completa	Connecting rod	Bielle	Pleuel	Biela
B	3850530A	Barra lame da cm.150 a 19 sezioni completa di attacco biella	Cutting bar	Barre de cupe	Mähbalken	Barra de corte
1	01614	Testa snodata d.14 filettatura interna PG 14	Ball head	Rotule	Kugelkopf	Bola
2	3850516A	Asta per biella BRM	Rod	Tige	Stange	Varilla
3	3850515A	Molla compressione d.20 D.32 L.46 filo d.6 4,5 spire molata	Spring	Ressort	Feder	Muelle
4	3850514A	Cilindro per biella BRM	Cylinder	Cylindre	Zylinder	Cilindro
5	3850518A	Rosetta biella BRM	Washer	Rondelle	Scheibe	Roseta
6	0623016	Dado basso PG 16 UNI 5589	Nut	Ecrou	Schrauben-mutter	Dado
7	3850513A	Piede di biella BRM	Support	Soutenir	Unterstützen	Apoyar
8	0673008100	Ingrassatore Dritto PF 8*1 UNI 7663 A	Grease nipple	Graisser	Gerader Öler	Engrasador
9	069046203	Cuscinetto 6302 2RS 40x17x12	Bearing	Coussinet	Lager	Almohadilla
10	06711040	Seeger per albero 40 UNI 7437	Seeger	Seeger	Seeger	Seeger
11	060524404242	Tubo da 3/8 R1T F.90 + F.90 3/8 L.4400 motore barra per versione idraulica	Hose	Tuyau	Schlauch	Tubo
11	060524254222	Tubo da 3/8 R1T F.90 3/8 + F.3/8 L.4250 motore barra per versione elettro-idraulica	Hose	Tuyau	Schlauch	Tubo
12	061011238	Niples M+M 1/2x3/8	Niples	Niples	Niples	Niples
13	0611212	Rondella in rame 1/2	Washer	Rondelle	Scheibe	Roseta
14	0641012040	Vite TE PG 12x40 UNI 5739	Screw	Vis	Schraube	Tornillo
15	0660112	Rosetta elastica grower 12 UNI 1751 A	Washer	Rondelle	Scheibe	Roseta
16	0129102210	Motore 100 cc	Motor	Moteur	Motor	Motor
17	06711040	Seeger per albero 40 UNI 7435	Seeger	Seeger	Seeger	Seeger
18	0650010020	Vite TCE 10x20 UNI 5931	Screw	Vis	Schraube	Tornillo
19	06710068	Seeger per foro 68 UNI 7435	Seeger	Seeger	Seeger	Seeger
20	069046008	Cuscinetto 6008 2RS 68x40x15	Bearing	Coussinet	Lager	Almohadilla
21	0641010030	Vite TE PG 10x30 UNI 5739	Screw	Vis	Schraube	Tornillo
22	0631010	Dado autobloccante normale PG 10 UNI 7473	Nut	Ecrou	Schrauben-mutter	Dado
23	3850519A	Pattino per barra zincato	Protection	protection	Schutz	protección
24	3850528A	Protezione barra BRM 150	Protection	protection	Schutz	protección
25	3850525A	Dente doppio SCH BRM	Blade	lame	Klinge	hoja
26	0631016	Dado autobloccante normale PG 16 UNI 7473	Nut	Ecrou	Schrauben-mutter	Dado
27	0660016	Rosetta piana 16 UNI 6592	Washer	Rondelle	Scheibe	Roseta
28	3850505A	Volantino biella BRM	Wheel	Roue	Rad	Rueda
29	3850511A	Supporto cuscinetti BRM	Support	Soutenir	Unterstützen	Apoyar
30	0646006020	Vite TE PG 6x20 UNI 5739 (10.9)	Screw	Vis	Schraube	Tornillo
31	0623006	Dado basso PG 6 UNI 5589	Nut	Ecrou	Schrauben-mutter	Dado
32	0631014	Dado autobloccante normale PG 14 UNI 7473	Nut	Ecrou	Schrauben-mutter	Dado

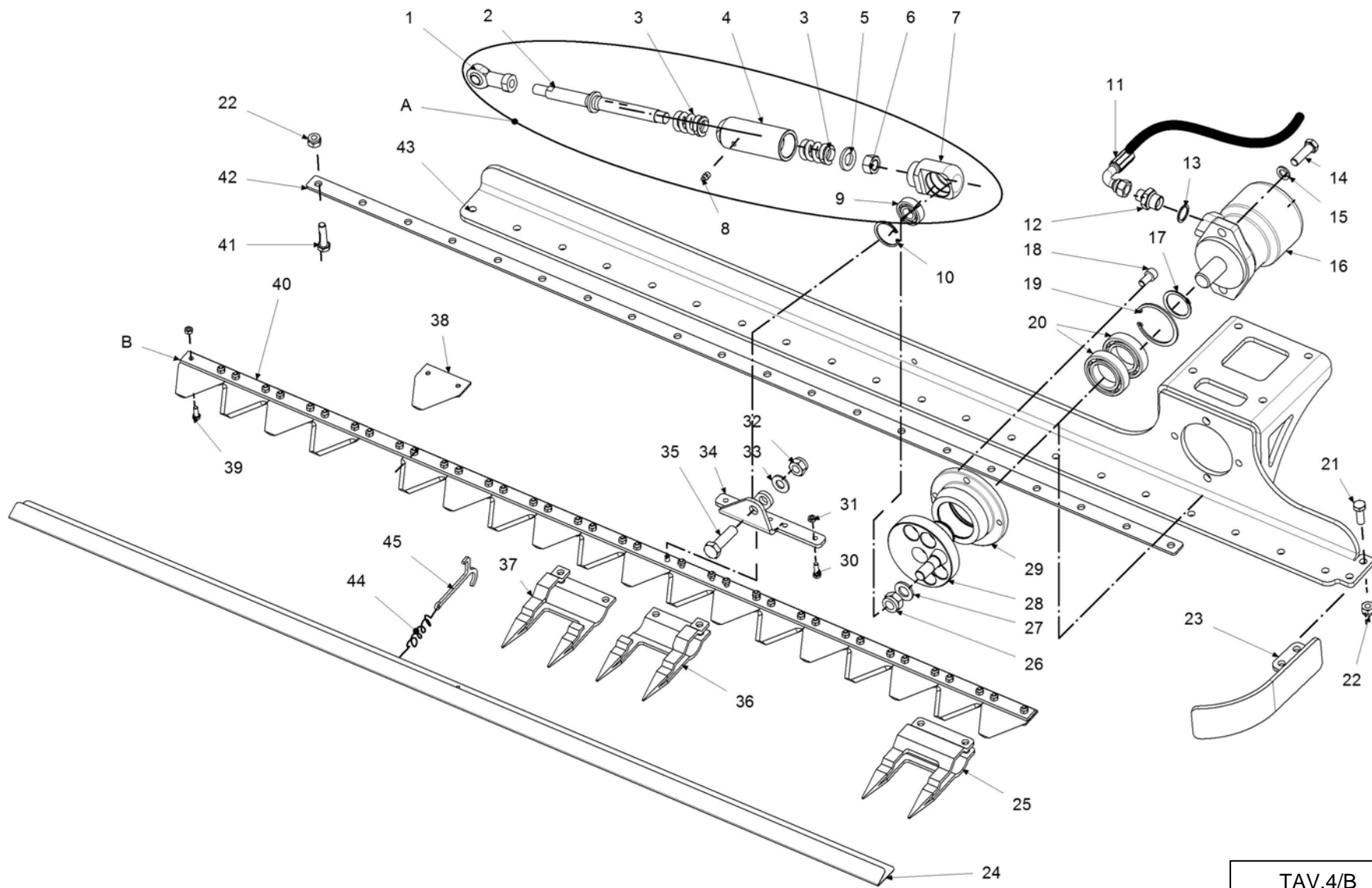

TAV.4/B

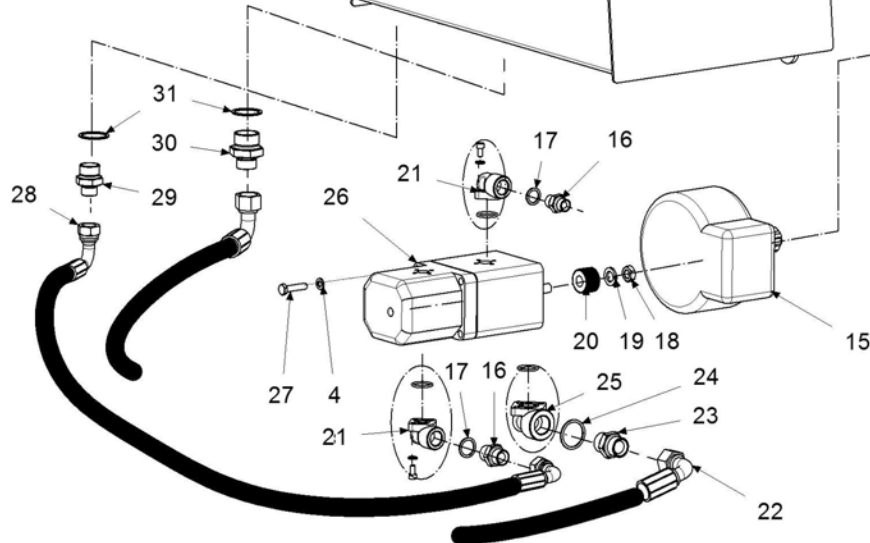
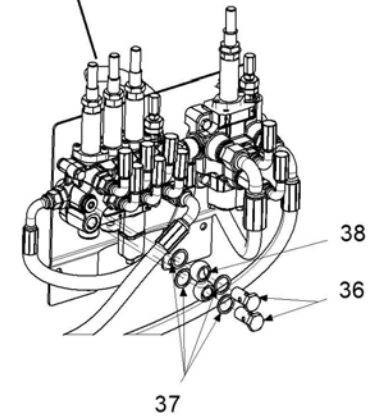
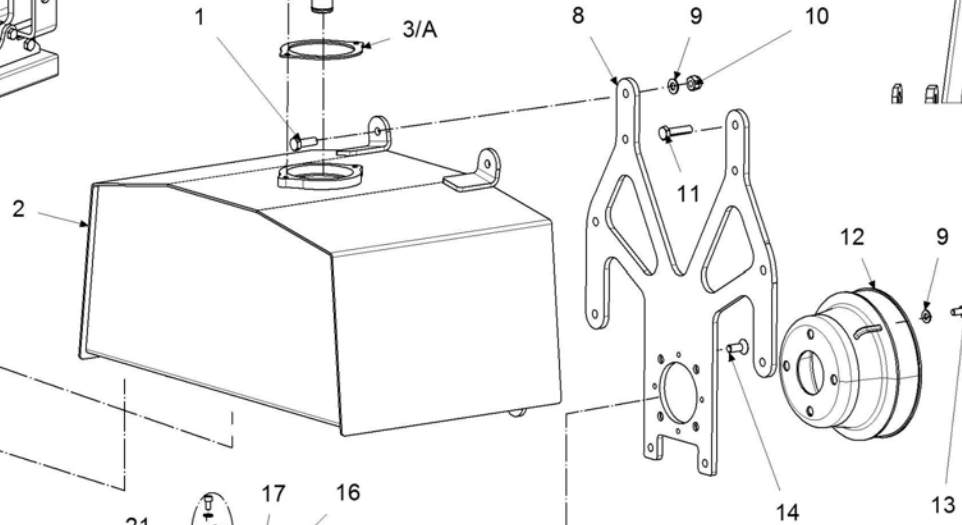
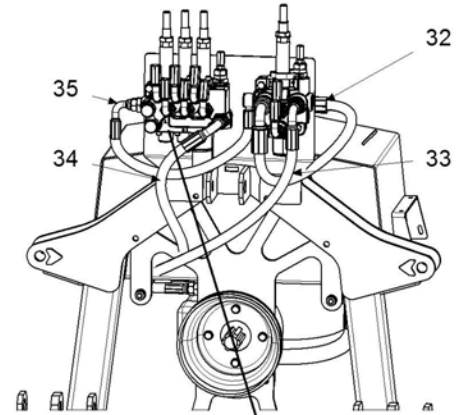
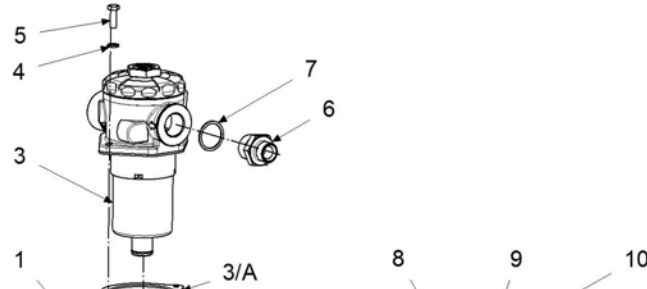
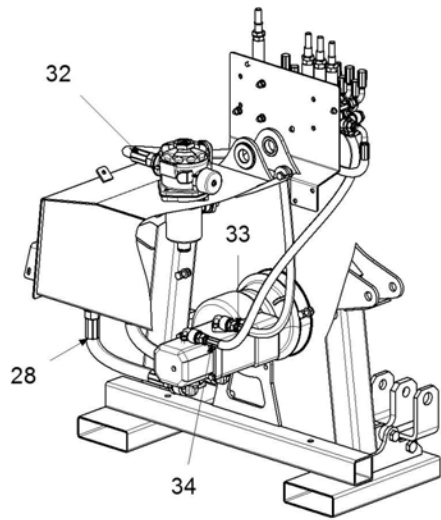

TAV.5/B

Parti di Ricambio “ BRM 150 “

Centralina Idraulica 3850400A

Tavola 5/B – Pagina 1

N°	Codice	Descrizione	English	Français	Deutsch	Español
1	0641010030	Vite TE PG 10x30 UNI 5739	Screw	Vis	Schraube	Tornillo
2	3850405A	Serbatoio olio	Tank	Reservoir	Tank	Depósito
3	01350	Filtro Olio 1" gas con sfiato aria	Filter	Filtre	Filter	Filtro
3/A	0135001	Guarnizione filtro in sughero con collare	Seal	Pare-huile	Ring	Para-aceite
4	0660108	Rosetta elastica grower 8 UNI 1751 A	Washer	Rondelle	Scheibe	Roseta
5	0641008020	Vite TE PG 8x20 UNI 5739	Screw	Vis	Schraube	Tornillo
6	061011012	Niples M+M 1x1/2	Niples	Niples	Niples	Niples
7	0611210	Rondelle in rame 1	Washer	Rondelle	Scheibe	Roseta
8	3850401A	Supporto serbatoio a telaio	Support	Support	Blech	Soporte
9	0660010	Rosetta piana 10 UNI 6592	Washer	Rondelle	Scheibe	Roseta
10	0631010	Dado autobloccante normale PG 10 UNI 7473	Nut	Ecrou	Schrauben-mutter	Dado
11	0641010035	Vite TE PG 10x35 UNI 5739	Screw	Vis	Schraube	Tornillo
12	07018	Cuffia protezione cardano	Protection	Protecteur	Sicherheit für Gelenkwelle-angriff	Casco
13	0641010016	Vite TE PG 10x16 UNI 5739	Screw	Vis	Schraube	Tornillo
14	0651001025	Vite TSCE 10x25 UNI 5933	Screw	Vis	Schraube	Tornillo
15	09014	Moltiplicatore gruppo 2 rapporto 1:3 albero maschio	Gearbox	Boite à engranage	Comer Getriebe	Grupo cónico
16	061011212	Niples M+M 1/2+1/2	Niples	Niples	Niples	Niples
17	0611212	Rondelle in rame 1/2	Washer	Rondelle	Scheibe	Roseta
18	0623012	Dado basso PG 12 UNI 5589	Nut	Ecrou	Schrauben-mutter	Dado
19	0660112	Rosetta elastica grower 12 UNI 1751 A	Washer	Rondelle	Scheibe	Roseta
20	17666	Giunto dentato per motore	Joint	Couplage	Kopplung	Acoplamiento
21	0612212	Raccordo a gomito 1/2 flangiato 3 fori per motori gruppo 2	Bend	Courbe	Kurve	Curva
22	060150754545	Tubo 3/4 R4 F.90 + F.90 3/4 L.750	Hose	Tuyau	Schlauch	Tubo
23	061013434	Niples M+M 3/4x3/4	Niples	Niples	Niples	Niples
24	0611234	Rondelle in rame 3/4	Washer	Rondelle	Scheibe	Roseta
25	061223/4	Raccordo a gomito 3/4 flangiato 3 fori per motori gruppo 2	Bend	Courbe	Kurve	Curva
26	01017	Pompa doppia gruppo 2 destra 20+11,2	Pumps	Pompe	Pumpe	Bombas
27	0641008045	Vite TE PG 8x45 UNI 5739	Screw	Vis	Schraube	Tornillo
28	060530604343	Tubo 1/2 R1T F90+F90 1/2 L.600	Hose	Tuyau	Schlauch	Tubo
29	061011012	Niples M+M 1x1/2	Niples	Niples	Niples	Niples
30	061011034	Niples M+M 1x3/4	Niples	Niples	Niples	Niples
31	0611210	Rondelle in rame 1”	Washer	Rondelle	Scheibe	Roseta
32	060530704323	Tubo 1/2 R1T F.90 1/2 + F.1/2 L.700	Hose	Tuyau	Schlauch	Tubo
33	060530954343	Tubo 1/2 R1T F.90 + F.90 1/2 L.950	Hose	Tuyau	Schlauch	Tubo
34	060531004343	Tubo 1/2 R1T F.90 + F.90 1/2 L. 1000	Hose	Tuyau	Schlauch	Tubo
35	060520505342	Tubo 3/8 R1T occhio 1/2 + F.90 3/8 L.500	Hose	Tuyau	Schlauch	Tubo

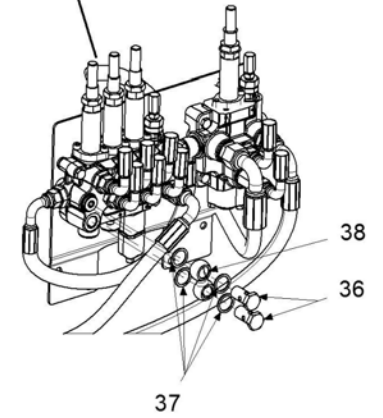
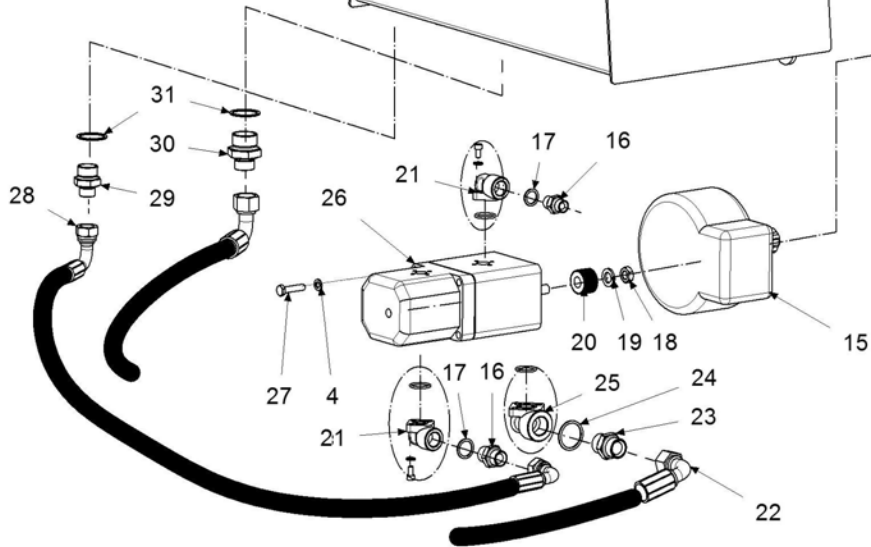
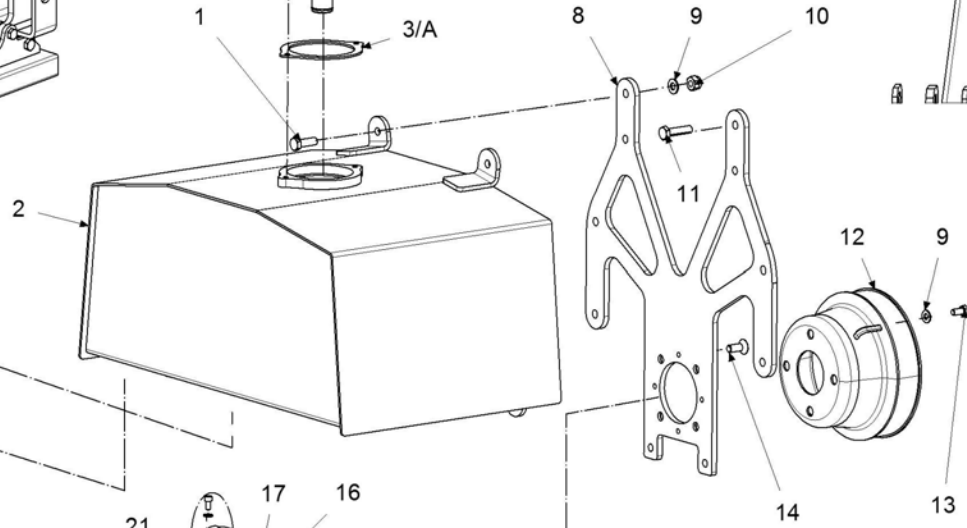
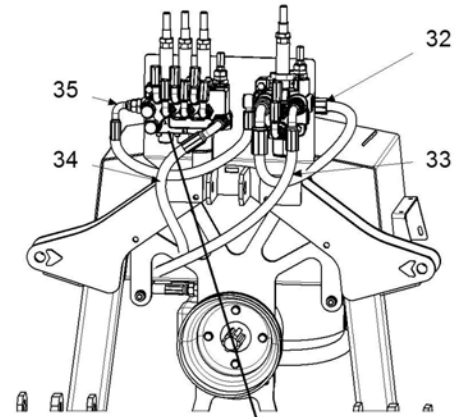
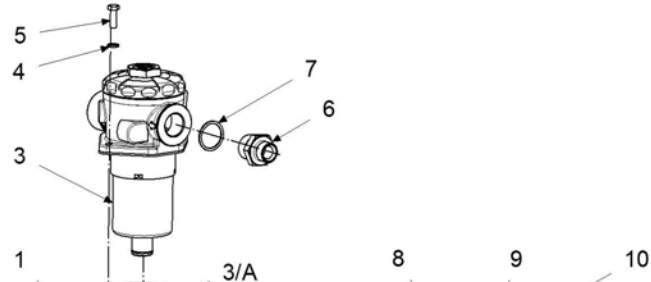
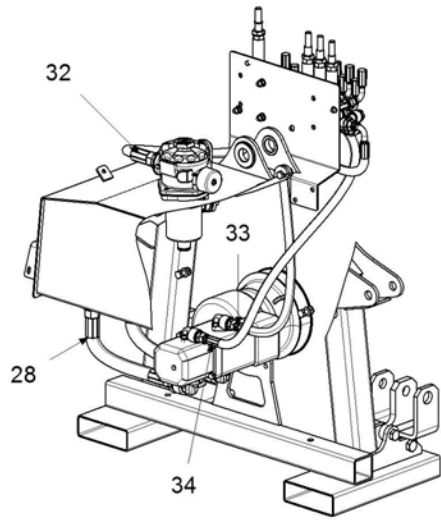

TAV.5/B

Condizioni di garanzia

La nostra azienda si riserva il diritto di apportare, in qualsiasi momento, eventuali modifiche per motivi di carattere tecnico o commerciale, pertanto le descrizioni e le illustrazioni contenute in questa pubblicazione sono aggiornate fino al momento della stampa. Le illustrazioni delle parti potrebbero essere diverse dai particolari montati sulla macchina, quindi solo il numero di codice rilevabile sul catalogo parti di ricambio determina la validità del pezzo.

Conditions of guarantee

The manufacturer reserves the right to modify the machines for commercial or technical motives, in every moment, therefore descriptions and illustrations of this publication are up to date until printing. If illustrations of tools or parts of the machine are different from this book, please refer to code number written in the spare parts catalogue.

Conditions de garantie

Notre entreprise se réserve le droit d'apporter, à tout moment, des modifications éventuelles pour des raisons à caractère technique ou commercial, c'est pourquoi les descriptions et les illustrations contenues dans cette brochure sont mises à jour jusqu'au moment de l'impression. Les illustrations des diverses parties pourraient différer des pièces montées sur la machine, seul le numéro de code, qu'on peut voir sur le catalogue des pièces de rechange, indique quelle est la bonne pièce.

Garantiebedingungen

Unsere Firma behält sich das Recht vor jederzeit evtl. Änderungen aus technischen oder kommerziellen Gründen vorzunehmen, deshalb entsprechen die in dieser Ausgabe vorhandenen Beschreibungen und Abbildungen dem aktuellsten Stand der Technik. Es besteht die Möglichkeit, dass die abgebildeten Teile mit den auf der Maschine eingebauten Teilen nicht übereinstimmen, deshalb ist zur Bestimmung des Teiles nur die im Ersatzteilkatalog aufgeführte Artikelnummer maßgebend.

Condiciones de garantía

Nuestra empresa se reserva el derecho de modificar las máquinas, en cualquier momento, por motivos técnicos o comerciales, por lo tanto las descripciones e ilustraciones que contiene este manual están confirmadas hasta el momento de la publicación. La ilustración de las piezas podría ser distinta de las piezas montadas en la máquina, por lo tanto sólo el número de código que se encuentra en el catálogo piezas de repuesto determina la validez de la pieza.